

# Locker Styles & Layouts

## Styles

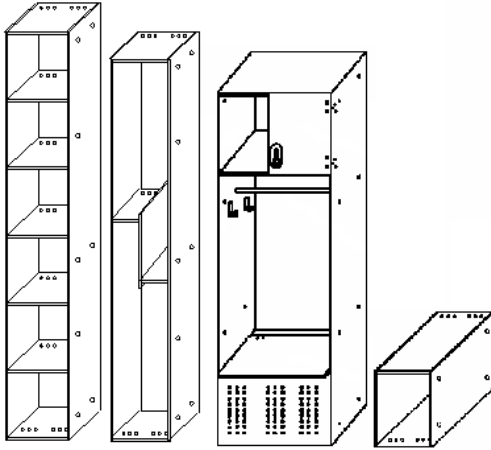

- 1 to 6 Tier Lockers
- Z-Style Lockers
- Athletic Lockers
- Cubbies

Any Custom Configuration  
All Available With ADA Options

## Layouts

- Free Standing Layout
  - Wall to Wall Layout
- Corner Locker Layout
- Island Locker Layout
- Peninsula Locker Layout

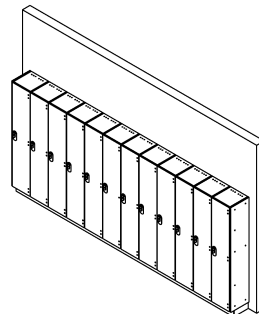

03132009 1

### 1 TIER LOCKER

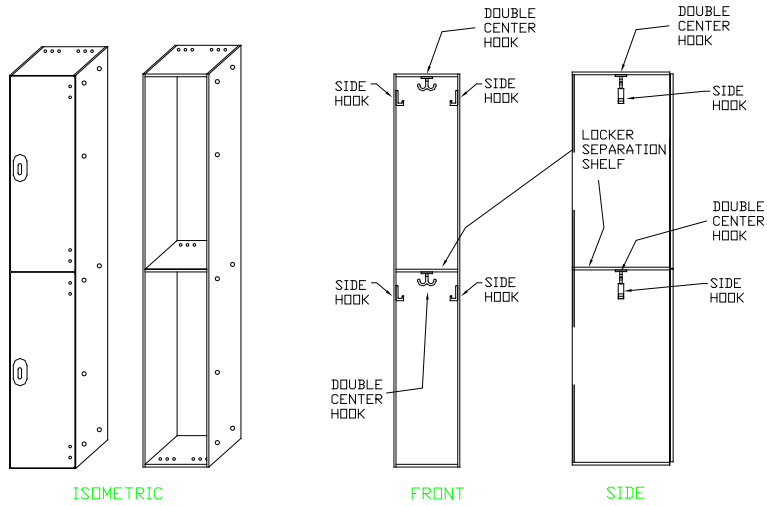
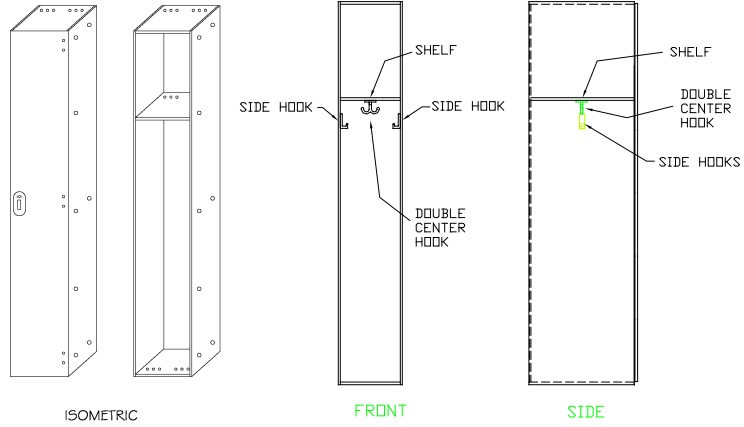

### 3 TIER LOCKER

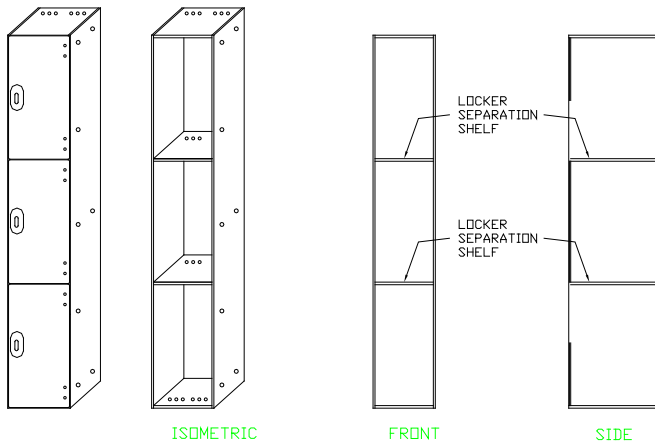

## 4 TIER LOCKER

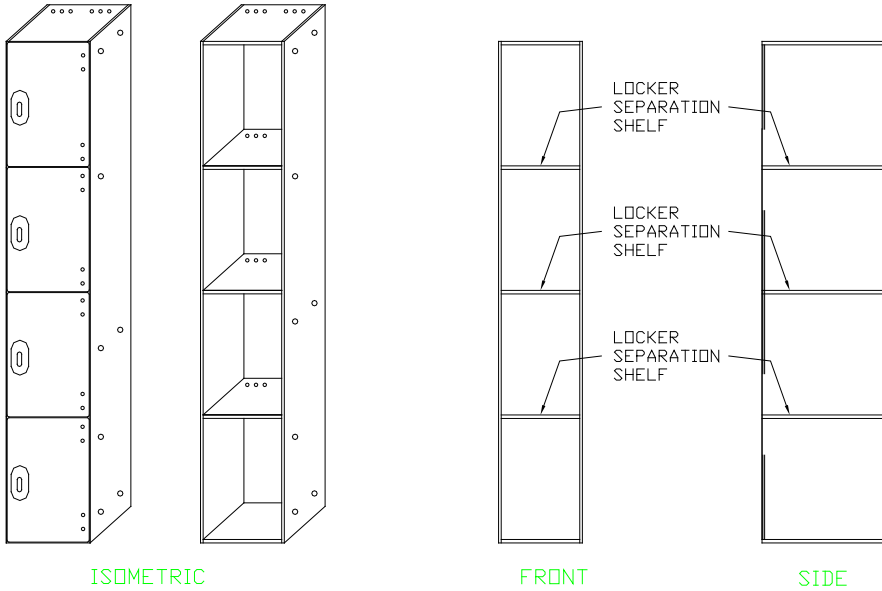

## 5 TIER LOCKER

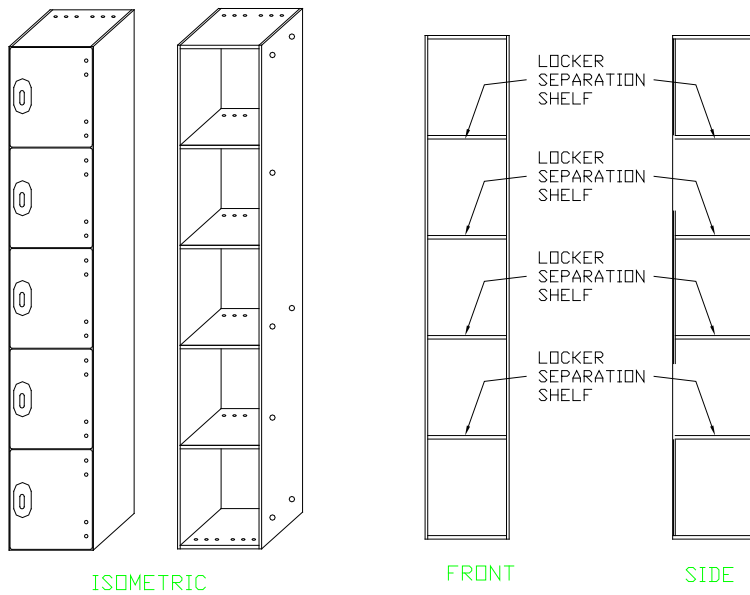

## 6 TIER LOCKER

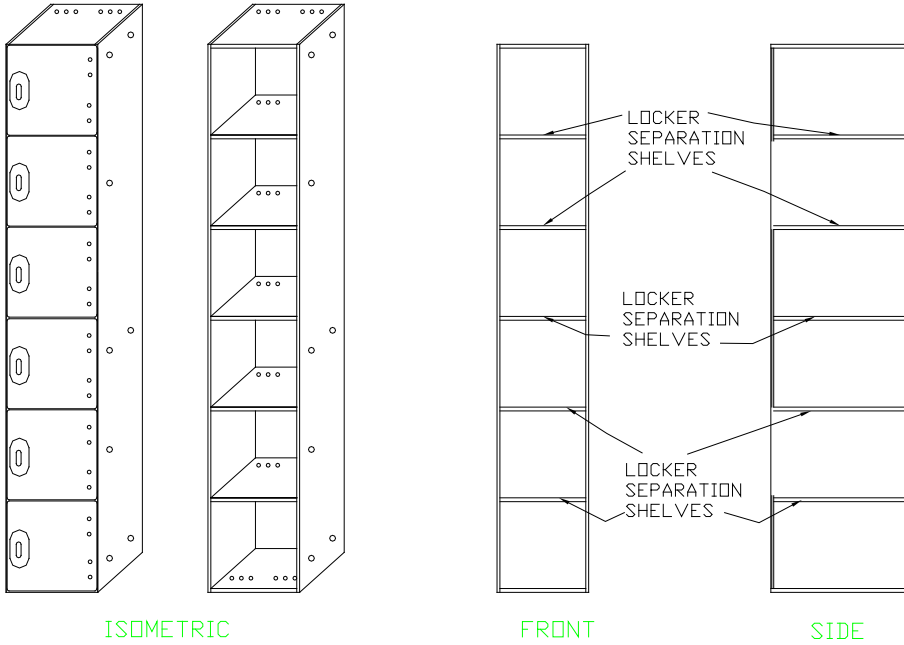

## Z LOCKER

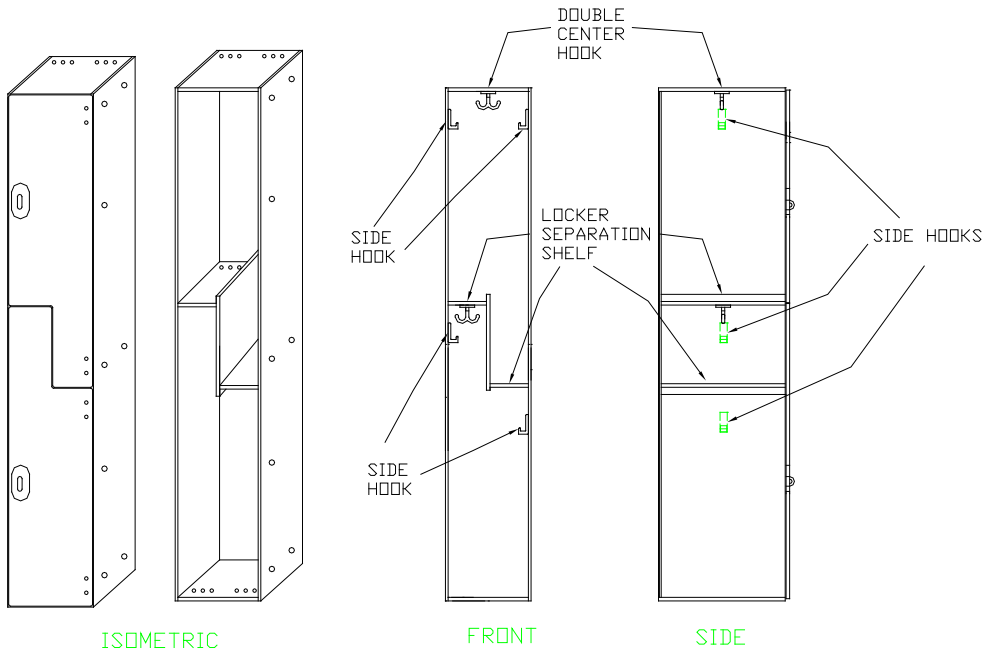

03132009 4

# ATHLETIC LOCKER

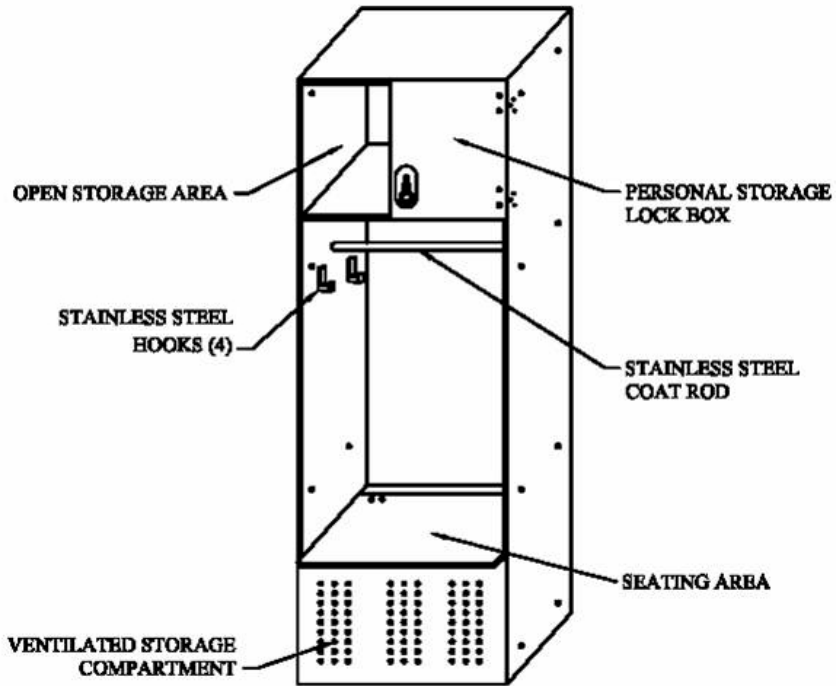

# ATHLETIC LOCKER

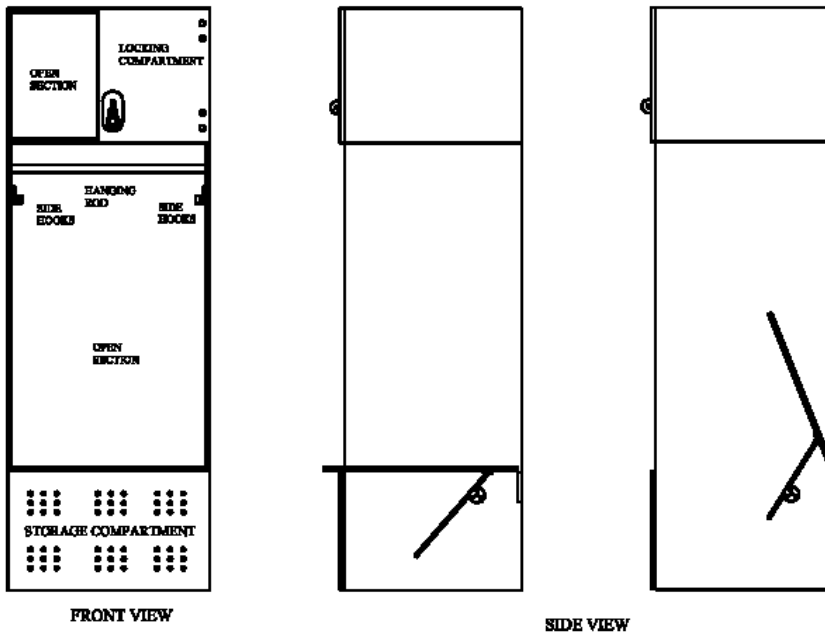

12 X 17 3/4 X 15

CUBBIE

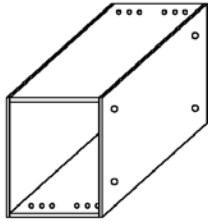

ISOMETRIC

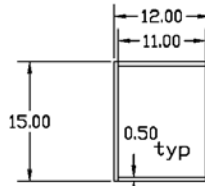

FRONT

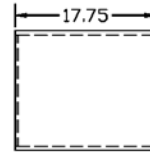

SIDE

12 X 12 X 59 3/4 5 TIER CUBBIE

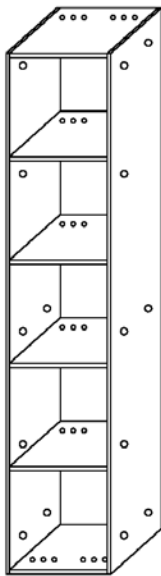

ISOMETRIC

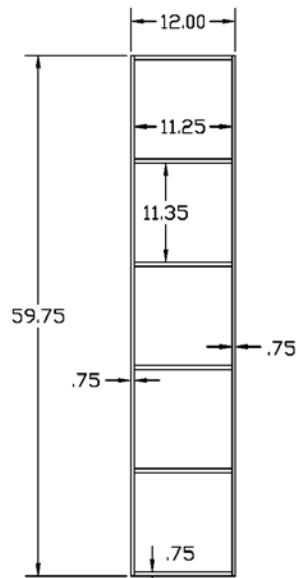

FRONT

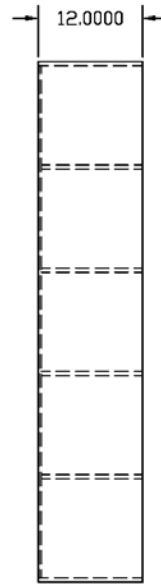

SIDE

# Free Standing Layout

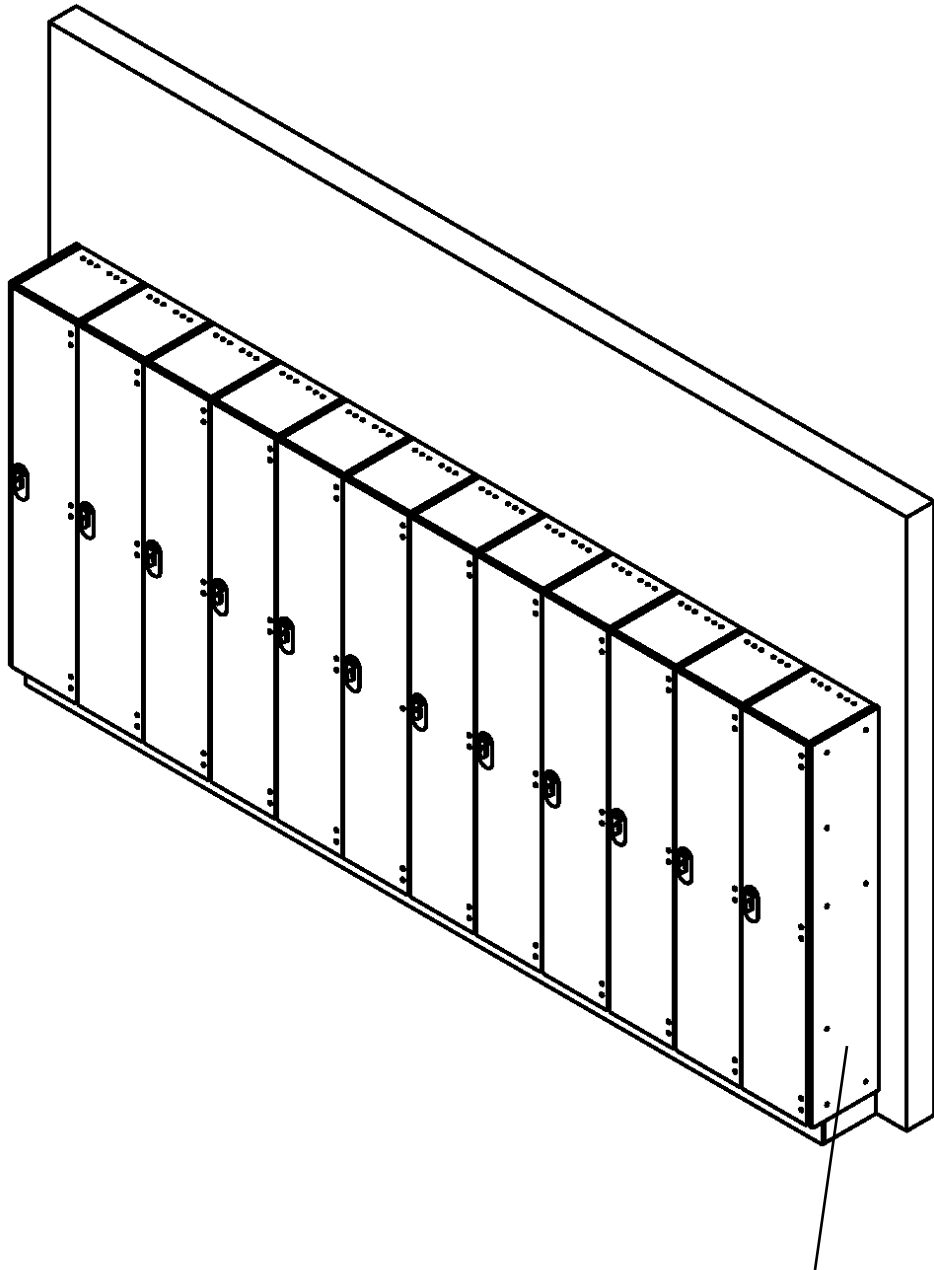

Finished End Panel  
on Both Ends

03132009 7

# Wall to Wall Layout

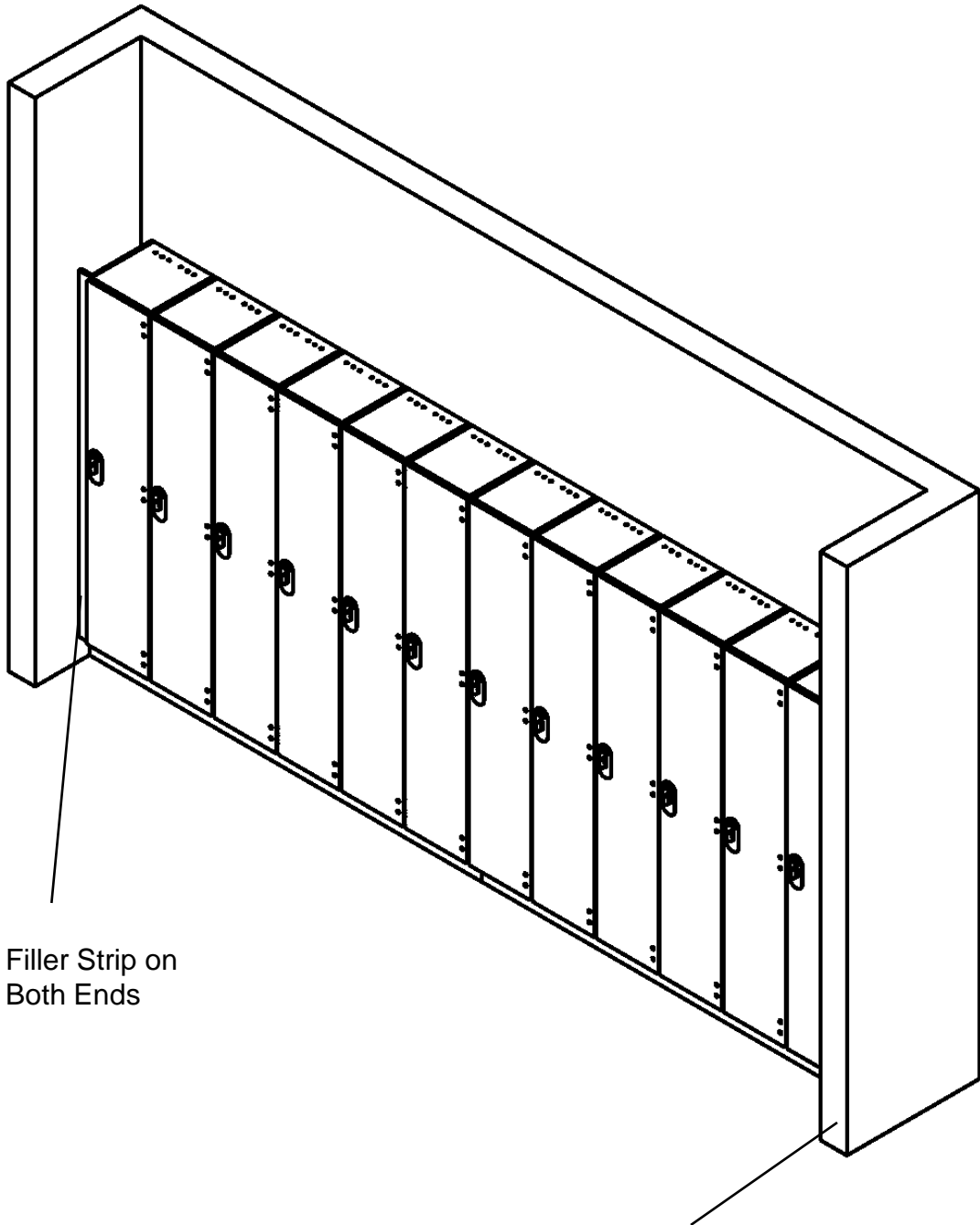

Filler Strip on  
Both Ends

Sub Wall to Extend Past  
Locker

03132009 8

# Corner Locker Layout

Formula For Corners = Depth  
Of Locker = 2" Minimum

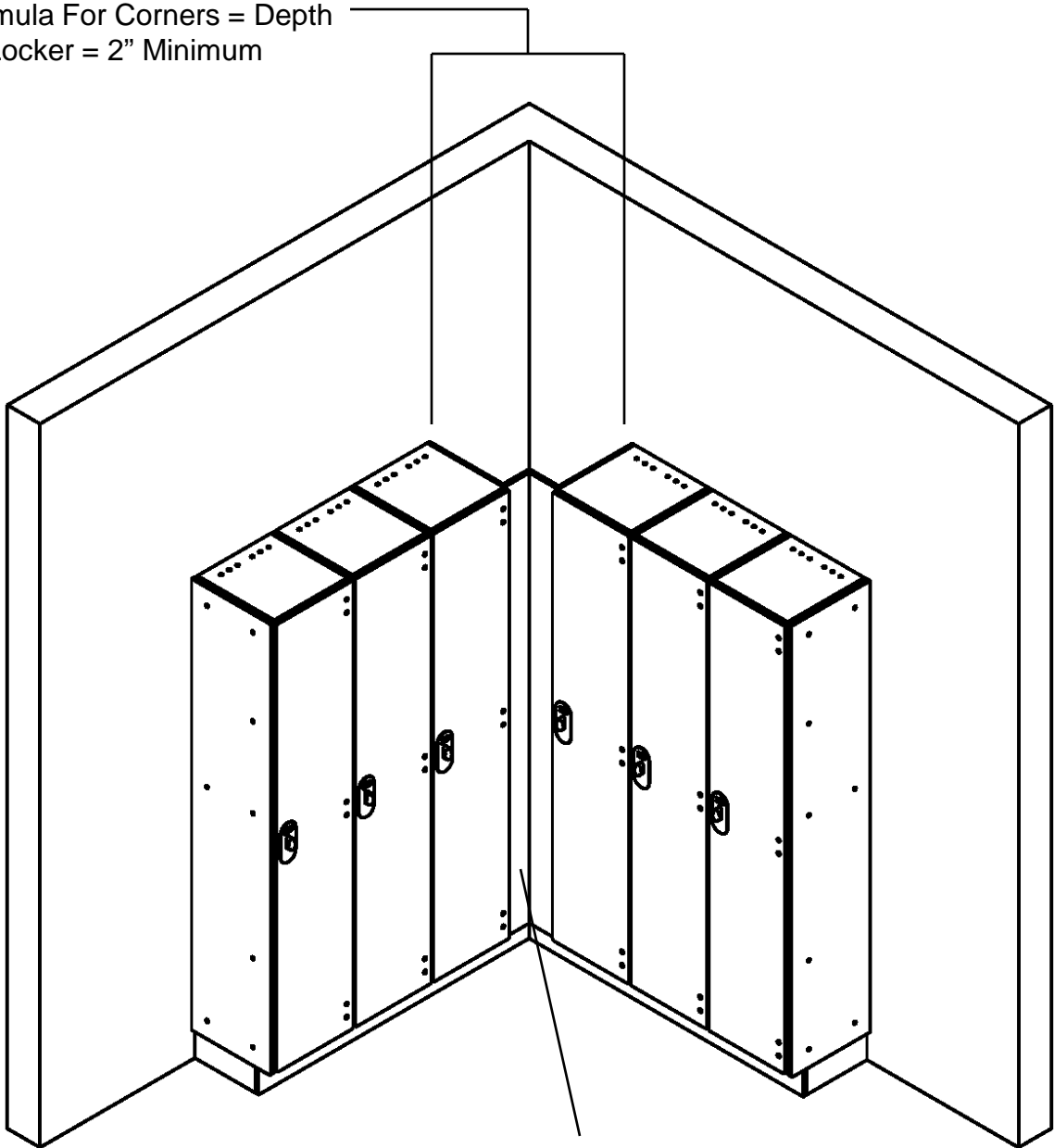

Filler Strips (2)

03132009 9

# Island Locker Layout

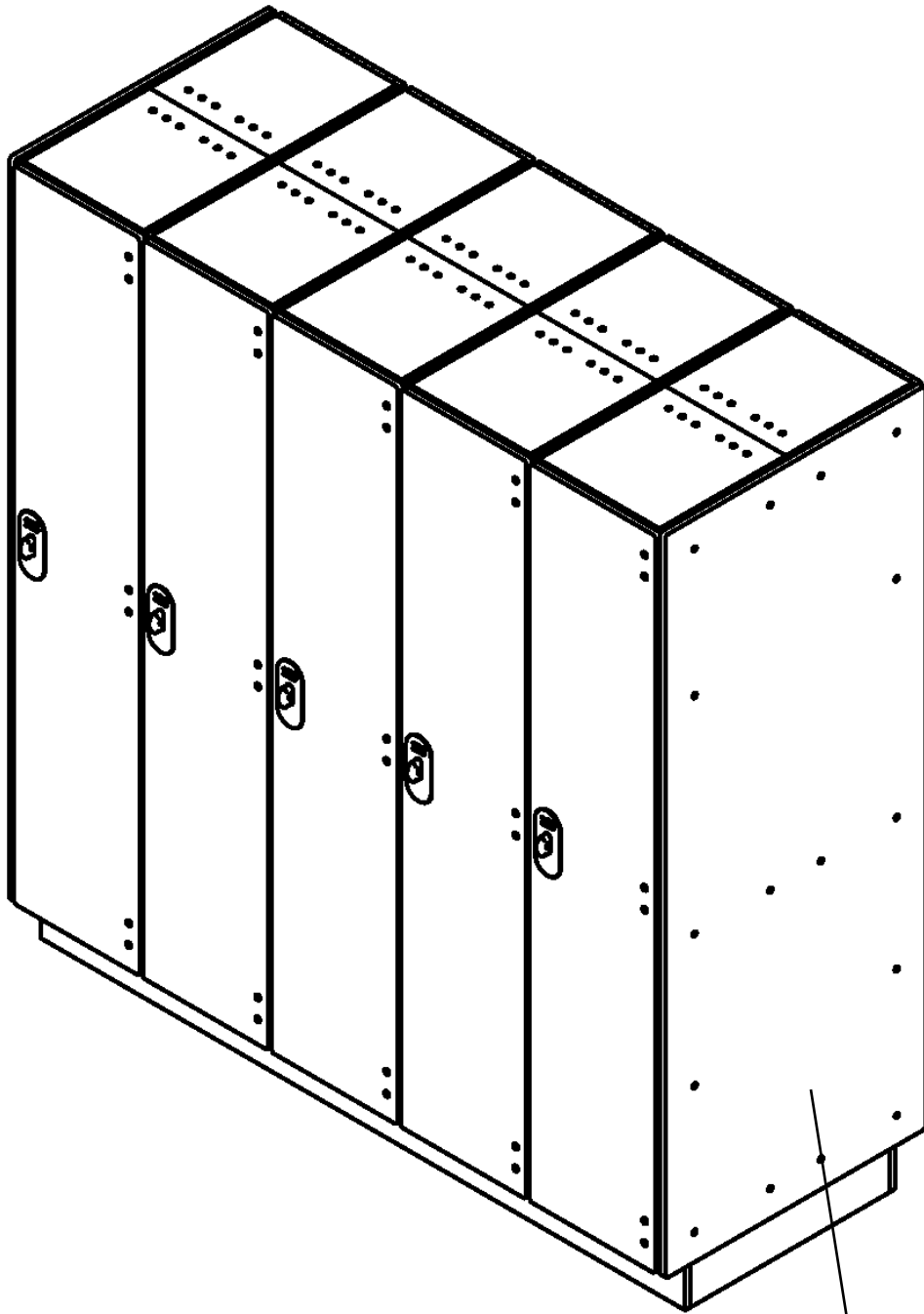

Double Finished End  
Panel On Both Ends

03132009 10

# Peninsula Locker Layout

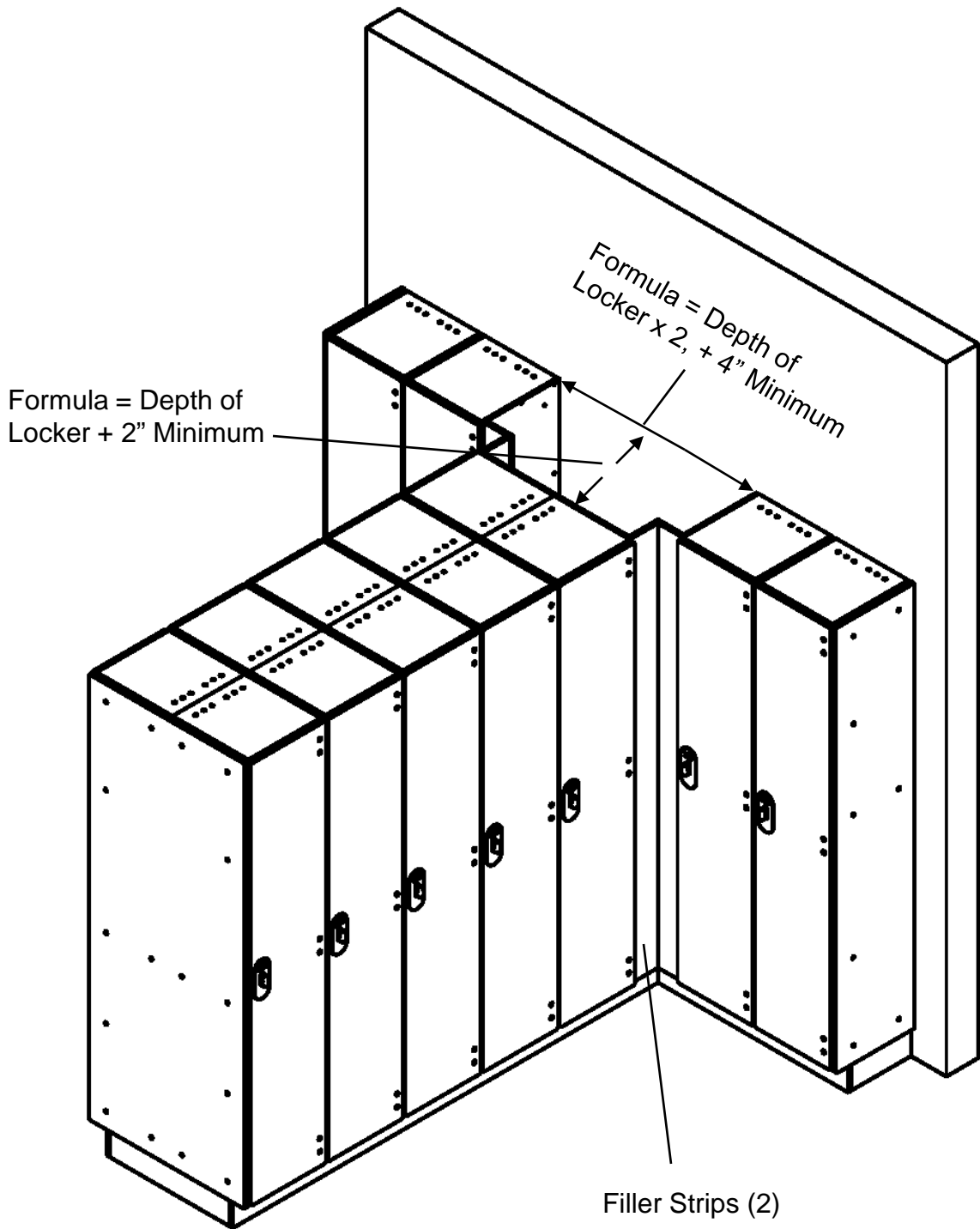

03132009 11