

Partition Layouts

- Alcove Layout
- Corner Layout
- Free Standing Layout
- Handicap Corner Layout
- Wall to Wall Layout

Alcove Layout

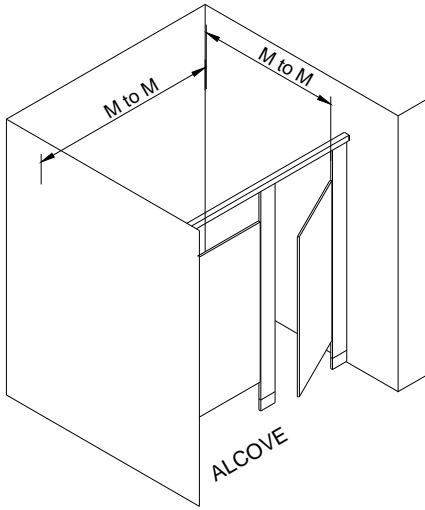

M to M = Made to Measure

Corner Unit Layout

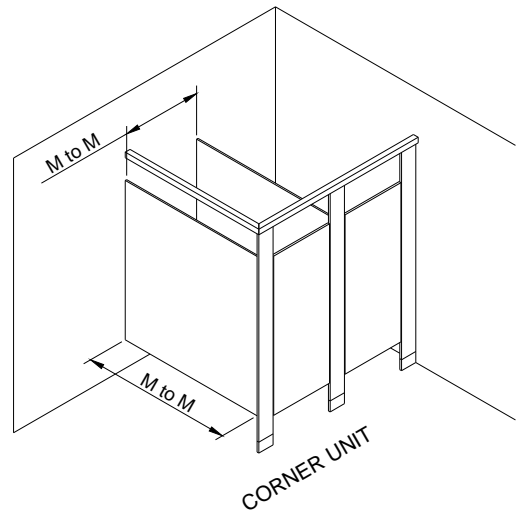

M to M = Made to Measure

03132009 2

Free Standing Layout

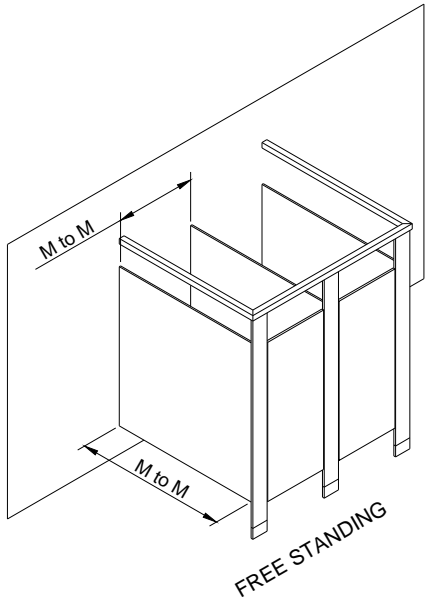

M to M = Made to Measure

Handicap Corner Layout

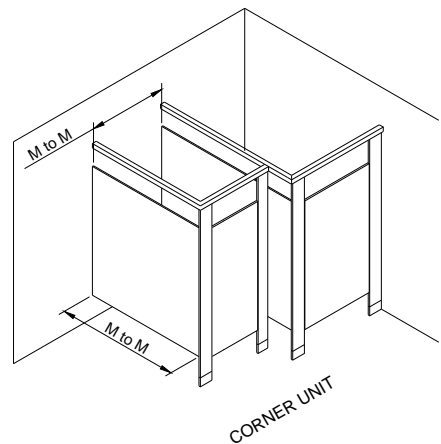

M to M = Made to Measure

03132009 3

Wall to Wall Layout

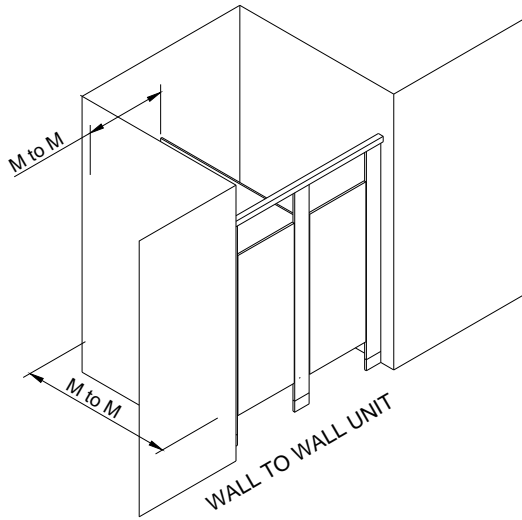

M to M = Made to Measure

Toilet Partition Styles

- Floor Mount Overhead Braced
- Floor to Ceiling Braced
- Ceiling Hung
- Floor Anchored

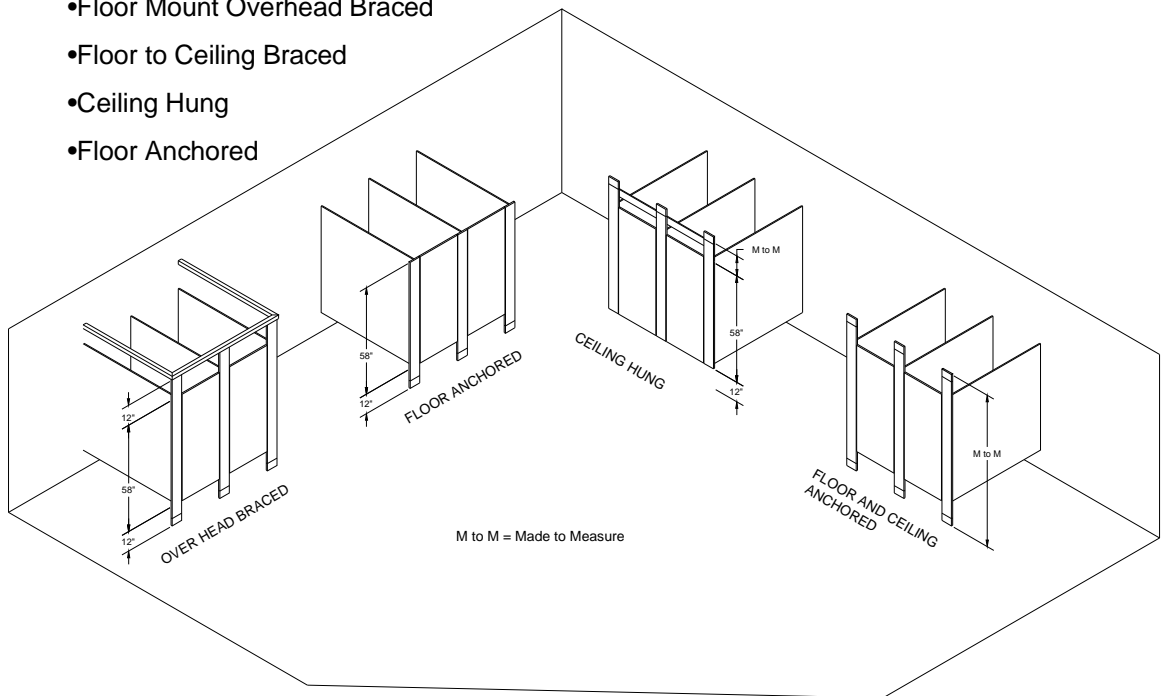

03132009

4

Floor Mount Overhead Braced

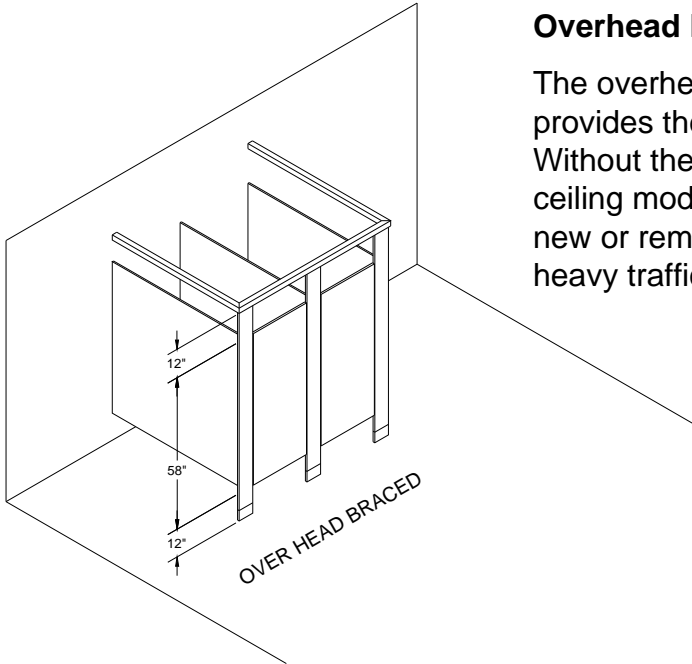

Overhead Braced Partitions:

The overhead braced style of partition provides the best solution for most facilities. Without the need for special floor and ceiling modifications, installation is simple in new or remodeled restrooms. It is ideal for heavy traffic and areas prone to vandalism.

Floor to Ceiling Braced

Floor to Ceiling Braced Partitions:

The floor to ceiling style toilet partition provides the next best solution for heavily used and abused restrooms. The strength of the partition is increased due to the two connecting points of the pilaster at the floor and the ceiling. A minimum of 3" concrete is required for installation to the floor. A structural support beam is required in the ceiling. This system is designed for ceilings up to 10 feet.

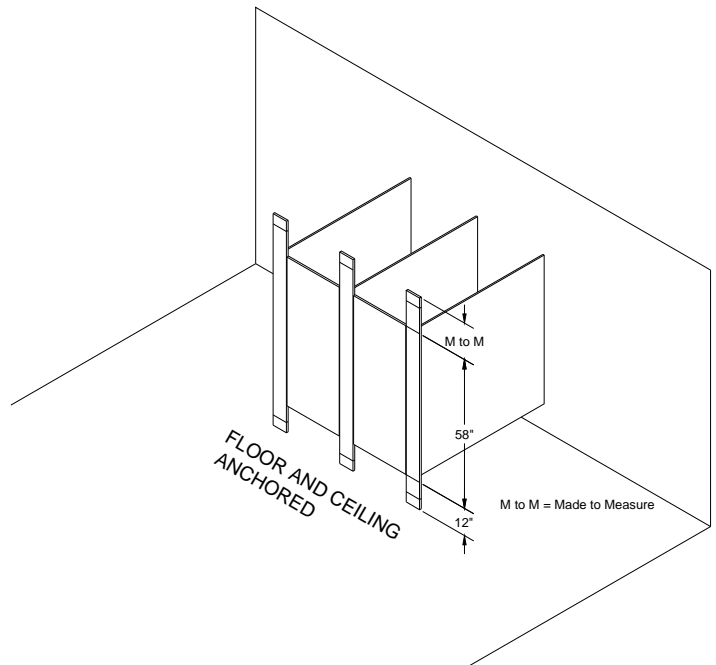

Ceiling Hung Partitions

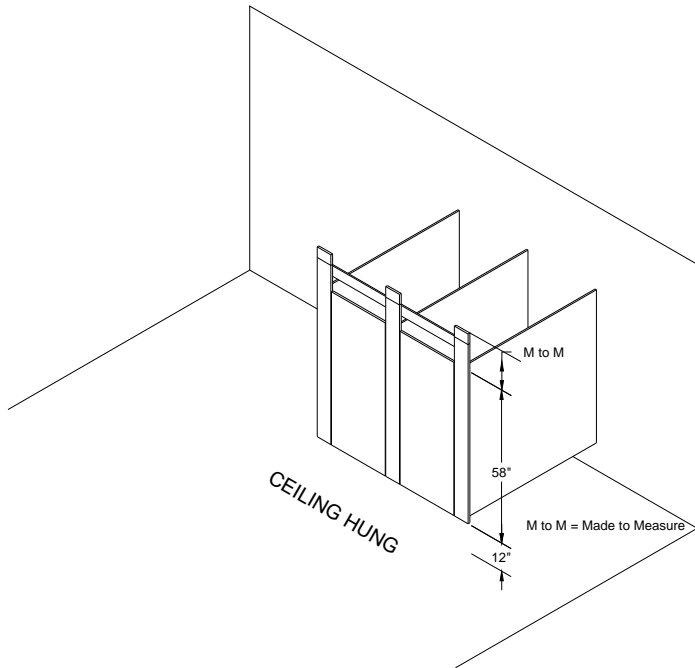

Ceiling Hung Partitions:

The ceiling hung style offers an area free from obstruction. It allows for fast and easy access to maintain the cleanliness of a restroom. The partitions require a structural support beam that the pilasters attach to. We have decreased the sway factor of the partitions by adding a support brace that provides maximum rigidity. The partitions are designed for room heights of 88" to 120".

Spec-Rite Designs has added an exception to the warranty of our ceiling hung DesignRite® Partitions. In order to uphold the integrity of our design, we must clearly state the way in which these partitions should be hung in order to uphold the intended design of the partition, while allowing us to warranty the craftsmanship. Spec-Rite Designs will continue to design and manufacture our line of ceiling hung DesignRite Partitions and our warranty for ceiling hung partitions.

Floor Anchored Partitions

Floor Anchored Partitions:

The floor anchored partitions offer an unobstructed spacious design feature which is ideal. A minimum of a 4" concrete base is required for secure attachment. These partitions are not recommended for a vandalism prone area.

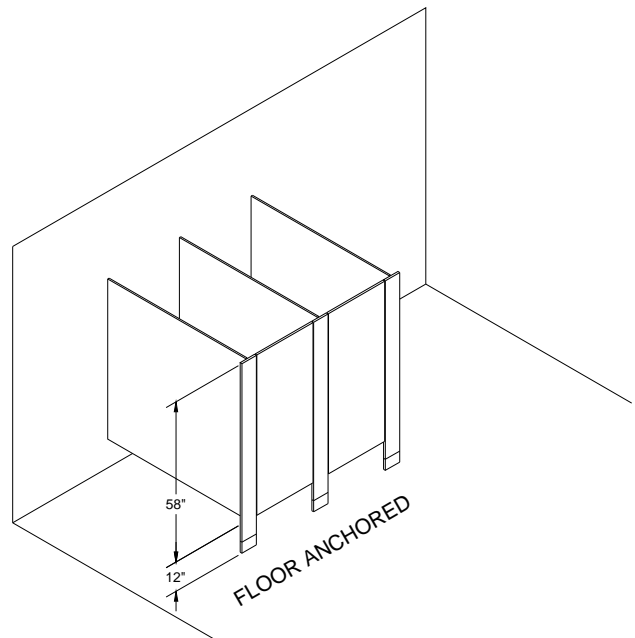

03132009 6