

Partition Hardware

- Standard Partition Hardware
- Optional Hardware (3)

Standard

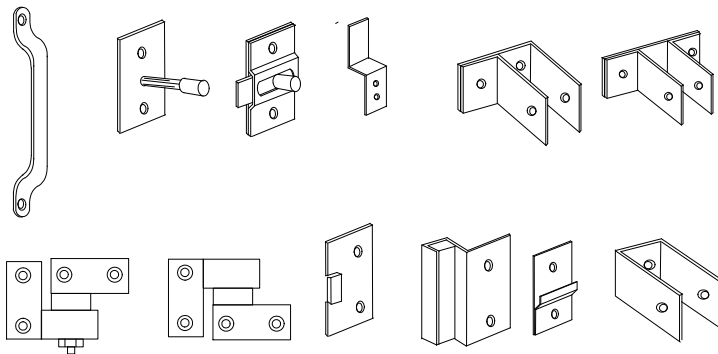

Optional Hardware

Option 1

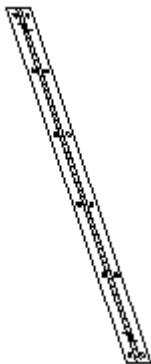

Option 2

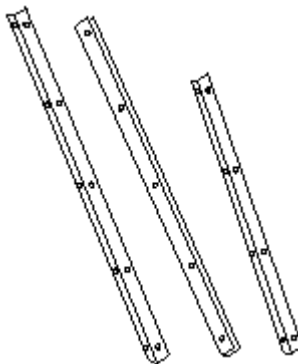

Option 3

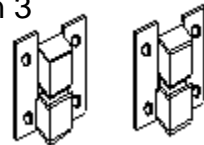

Standard Partition Hardware

The standard partition hardware is recommended for commercial and industrial facilities, restaurants, airports and schools. It is suitable for high traffic and vandalism prone areas. The hardware package contains 3 brackets per wall to panel, panel to pilaster and pilaster to wall connections. The door hinge is a pivot type ball bearing cam system designed to hold the door open to any degree or allow the door to return to the fully closed position. The door hinge uses a set of bearings that roll on the cam and uses gravity to return the door to the preset position. Each door is equipped with a slide latch, keeper, doorstop and separate coat hook. The hinge, slide latch and keeper are designed with an emergency lift feature. This will allow the door to be opened without any special tools or destruction to the partitions. Each partition is provided with 304 grade stainless steel brackets and the fasteners are one-way headed 18-8 stainless steel. The use of one-way headed, thru-bolted connections are provided for strength and security. The standard hardware is ideal for shower and toilet partition applications.

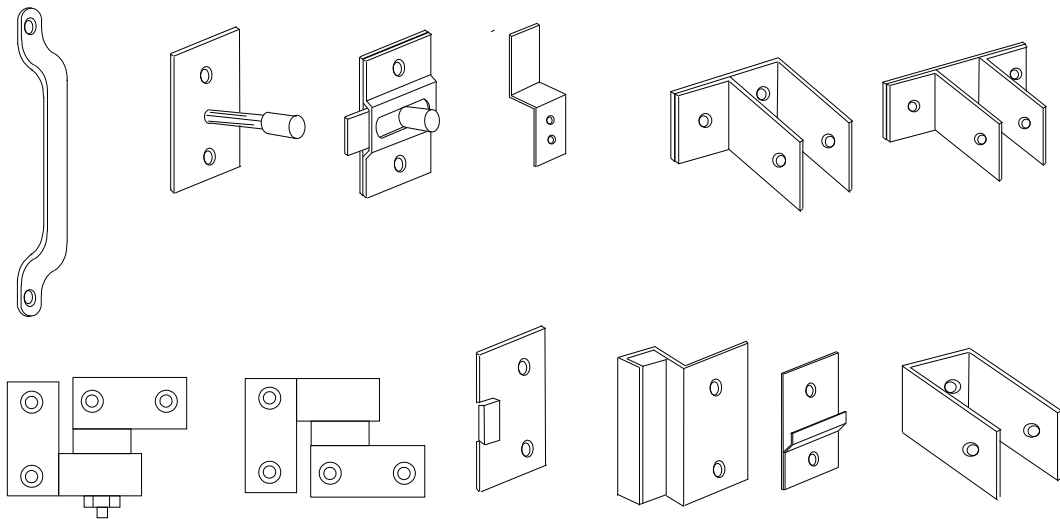

Optional Partition Hardware

Option 1 and 2 are recommended for industrial facilities, prisons and schools. It is suitable for high traffic and vandalism prone areas. The hardware package contains full height brackets for wall to panel, panel to pilaster and pilaster to wall connections. The door hinge is a spring-loaded continuous piano hinge system designed to allow the door to return to the fully closed position.

Option 1

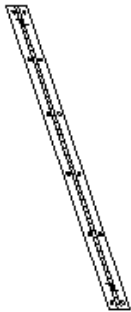

Option 2

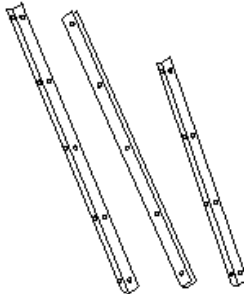

Option 3 is an alternate hinge also recommended for commercial and industrial facilities, restaurants, airports and schools. It is suitable for high traffic and vandalism prone areas.

Option 3

